

Autocascade Vacuum Pump Cold Trap Chiller

Modified Window Air-Conditioner and Connected Cold Trap for -30°C Operation

Designer: Michael St. Pierre

Date: May 29th 2007

Purpose

To implement an environmentally safe method of flushing contaminants, and excessive oil out of a refrigeration unit being serviced. Alcohol was found to be a very effective solvent, which neither caused harm to the unit, or the environment. However there was a catch to this solution, and it became a significant problem in its own right. Residual alcohol left in the system (trapped in phase separators), would overwhelm the capabilities of the vacuum pump during unit evacuation, and contaminate its oil. A trapping system between the refrigeration unit and the vacuum pump was urgently needed.

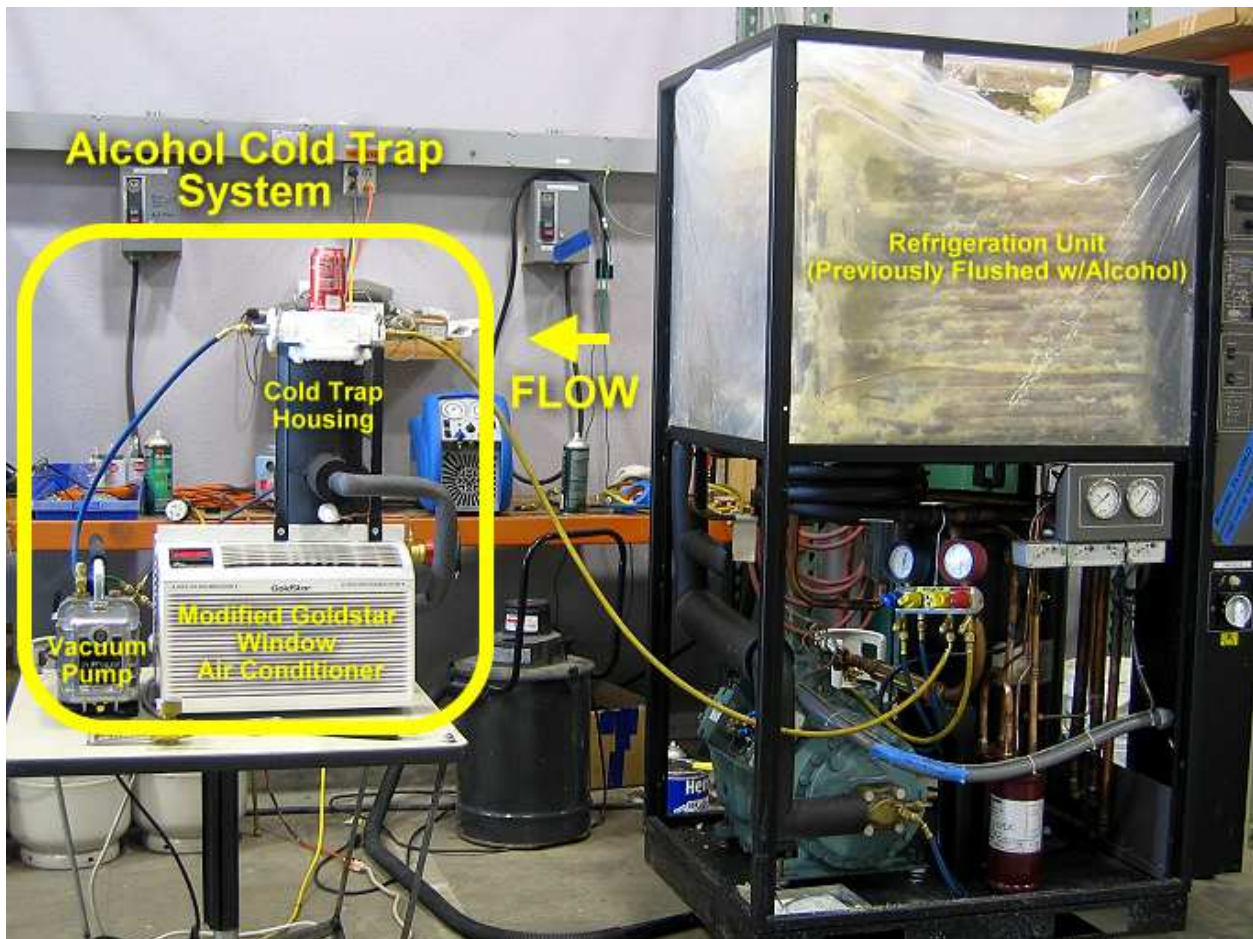

Trying to keep the price reasonable meant building our own trapping system. A window air-conditioner became a suitable candidate since they can be purchased from nearly any home improvement store. Of course in the Tim Allen “Home Improvement” tradition, it did require some rewiring, and re-plumbing to bring this concept fully into reality.



LG Goldstar GWHD5000
5000 BTU Window Air Conditioner
120 VAC Operation
Sells for about \$100 at Home Depot
Compressor: QA075CDE 1/2 HP rotary
Displacement: 7.5cc/rev

Autocascade Piping Diagram

HEAT EXCHANGERS = 3/16" OD TUBING inside 3/8" OD Tubing
(EACH HEAT EXCHANGER IS 10 FEET LONG)

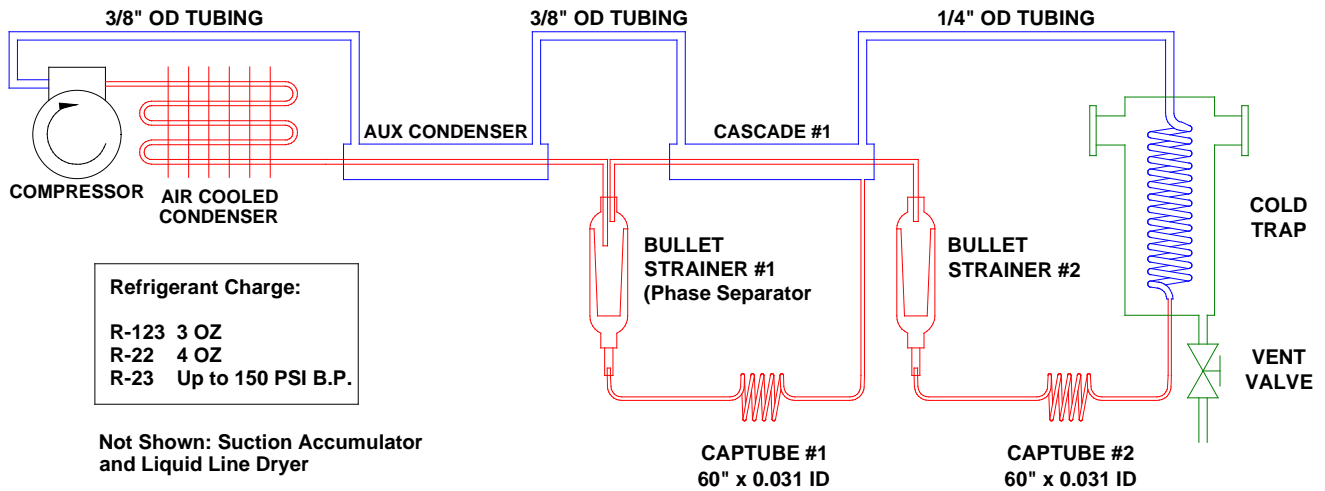

Physical Arrangement of Autocascade

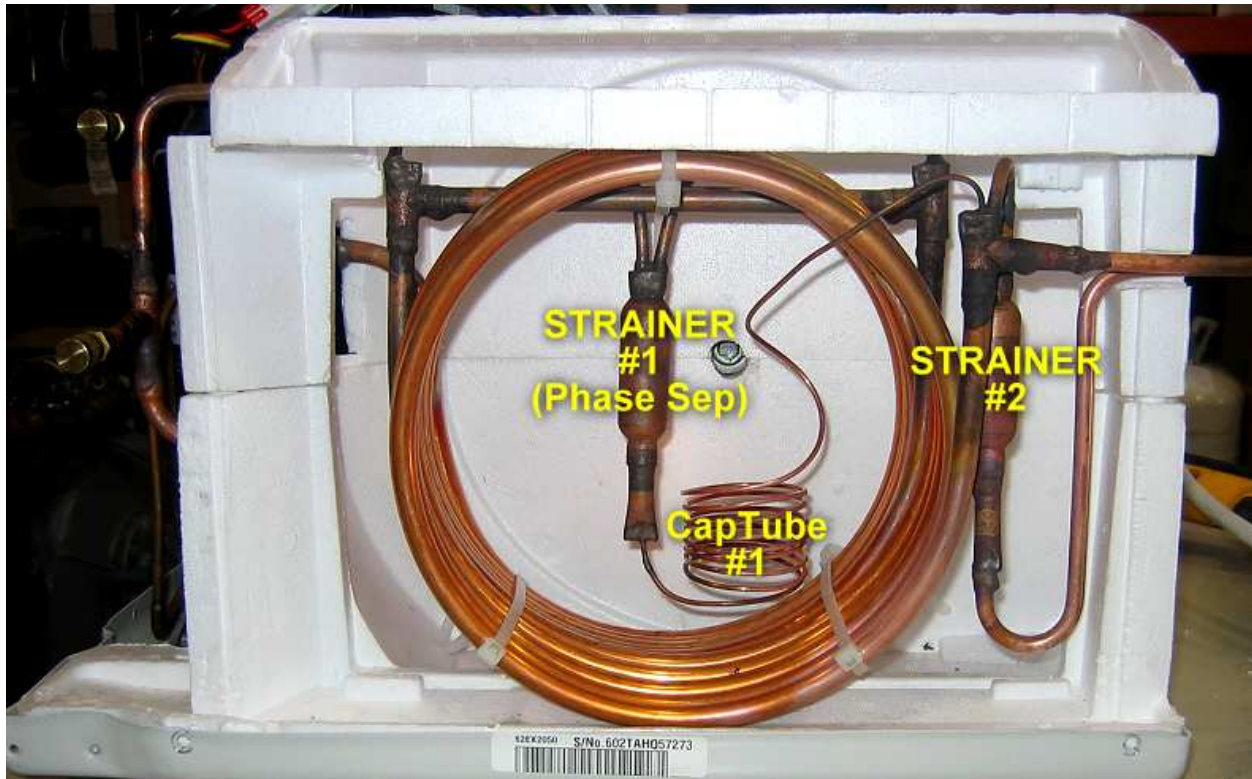

The autocascade heat exchangers reside in the space once occupied by the stock evaporator, and circulation fan. This area will later be insulated with self-expanding polyurethane closed cell foam.

Although the ideal orientation of the heat exchangers should be in a horizontal plane for better suction side return, due to the size and shape of the available space, a vertical orientation worked better for our design (velocity was considered to be sufficient for oil return).



Creating The Unit

A bullet style liquid line filter dryer w/charging port (Supco p/n SUD 115), and a suction access valve are added to the original condensing unit.

In the initial design, the suction access valve was pointed towards the front of the unit. It was later discovered that this interfered with the electrical compressor control assembly, and was then rotated 180 degrees to face back towards the compressor.

The autocascade heat exchanger assembly

fit quite nicely inside the original Styrofoam evaporator/fan enclosure.

With a little bit of plastic sheeting, a piece of plywood to contain the foam when it expanded, and a bit of luck, it became an insulated housing for our new autocascade heat exchanger stack.

Later after the foam cured, the top was cut to mimic the same angle of the outer plastic case, and then sealed with wet patch roof cement (this prevents moisture in the room, that would have eventually entered through the cut section, from saturating the foam insulation).



Next the cold trap was connected, leak checked, evacuated, and the refrigerant charge was added (placed the unit on an electronic charging scale).

The system was started up for a quick test run to verify that the captubes were flowing, and of course to see the cool looking ice forming over all the exposed refrigeration piping. It only took a few minutes to achieve frostbite temperatures.

The final captube was wound around the 1/4" od return line mostly for reasons of creating an easily insulated line, but I do suppose we are also getting some useful subcooling due to the direct contact with the cold return line.

With every thing appearing to be operational, the final wiring was completed, and reassembly of the original enclosure commenced.



Here's a birds-eye view of the connected cold trap (modified vacuum pump exhaust filter housing). Inside can be seen the evaporator assembly which consists of a 12" length of 1 5/8"od copper tubing with 1/4"od tubing coiled around and brazed to its outside surface.

Copper scouring pads are stuffed down the center in order to hopefully "scrub" (intentional pun) the incoming gas stream of any alcohol that is present.

Custom made white Delrin insulating blocks are used on both the top and the bottom to hold the cold element in place, and to form a seal, thereby forcing the

incoming gases to flow through the element's center section.

Although it can't be seen in the photo above, there are a multitude of 5/16"od holes drilled down the sides of the 1 5/8"od tubing to allow the alcohol free gases to escape and travel back out of the cold trap housing.

A thermocouple was attached to the return line just as it leaves the stainless steel feed-thru, and similar to the final captube, was spirally wound around the return line (this is to be later connected to a panel mounted TC Meter).

Final Packaging

Well with a little bit of persuasion, all the original "skins" were replaced, and a new temperature readout display was installed.

The mounted cold trap and interconnection line were insulated, and the upper flange with con-flat adapters installed.

Testing

Within 10 minutes we achieved a return temperature of -31°C, while the cold trap housing was under constant evacuation.



After 30 minutes run time, the temperature had dropped only another 0.7°C (equilibrium had been reached). Compressor pressures were 20 psig suction and 100 psig discharge (very comfortable).



This temperature (-31°C) is well beyond the -9.0°C requirement for condensing alcohol at 10 mmHg (lowest possible pressure level with a standard mechanical vacuum pump). Success!